

# UNITÀ FILTRANTI E FILTRO-ASPIRANTI FISSE



**STATIONARY UNITS AND FILTER FILTERING AND EXTRACTING  
UNITÉS FIXES POUR LA FILTRATION ET L'ASPIRATION  
FESTE EINHEITEN ZUR FILTERUNG UND ABSAUGUNG  
MAQUINAS ASPIRANTES FILTRANTES CON FILTRO FIJAS**



# SUPERJET-DF



Il nuovo filtro a cartucce orizzontali SUPERJET-DF trova applicazione nell'aspirazione e filtrazione di fumi di saldatura, polveri grossolane e fini, trucioli in modesta quantità, polveri/fumi da taglio termico. Il gruppo è costituito da una precamera, dove la maggior parte delle polveri grossolane viene separata e si deposita nel primo cassetto di raccolta; il successivo labirinto e la sezione filtrante con cartucce ad alta efficienza provvedono alla filtrazione delle polveri residue. Il ventilatore ad alto rendimento, posto nella parte alta dell'unità, garantisce un'elevata capacità di aspirazione ed una bassa rumorosità.



The new SUPERJET-DF equipped with horizontal cartridges is suitable for suction and filtration of welding fumes, fine and coarse dusts as well as of small quantities of chips, dusts/fumes from thermal cutting. The filter unit consists of one pre chamber, where the most dusts are sorted out, falling then in the first collecting bin. The following labyrinth together with the high efficiency filtering cartridges and the second collecting bin complete the filtration of the remaining dusts. The high performance fan, placed just on the top of the unit, assures a high suction capacity and a low noise level.



Le nouveau filtre a cartouches horizontale SUPERJET-DF a été conçu pour l'aspiration et la filtration des fumées de soudure, poussières, de la plus fine a la plus grossière, certains types de copeaux en faible quantité, poussières et fumées de découpe laser. Le groupe est constitué d'une préchambre de décompression dans laquelle la majeure partie des polluants sont séparés et se déposent dans le premier caisson de récupération. La chicane qui suit et la partie filtration constituée de cartouches filtrantes a tres haute efficacité permettent une filtration des poussières résiduelles. Le motoventilateur a haut rendement, positionné dans la partie haute du groupe, fonctionne en dépression, assure une grande capacité d'aspiration et une niveau sonore particulièrement faible.



Das neue Filtergerät mit horizontalen Filterpatronen SUPERJET-DF findet die optimale Anwendung bei der Absaugung und Filtration von Schweißrauch, feinen und groben Stäuben, kleine Mengen an Späne, sowie Stäube und Rauch aus Laser- und Plasmaschneiden. Das Gerät besteht aus einer Vorkammer, bei welcher die groben Stäube bereits abgeschieden werden und sich in den ersten Behälter aufsammeln; das nachstehende Labyrinth und die Filterkammer mit Hochleistungspatronen gewährleisten die Filtration der Reststäube. Der im oberen Teil des Gerätes angeordnete Ventilator garantiert eine hohe Saugleistung und einen niedrige Lärmemission.



El nuevo filtro SUPERJET-DF con cartuchos horizontales, encuentra aplicación en la aspiración y filtración de humos de soldadura, polvos finos y gruesos en cantidades limitadas y polvos/humos procedentes de corte termico. El equipo está constituido por una pre cámara, donde se produce una primera pre-separación de la mayor parte de los polvos, que se depositan en el primer cajón de recolección. A seguir hay un laberinto y una sección de filtración con cartuchos de alta eficiencia donde se produce la filtración de los polvos residuos. Estos polvos residuos se depositan en el segundo cajón de recolección. El aire filtrado, atraviesa el ventilador de alto rendimiento, situado en la parte superior del filtro que garantiza una elevada capacidad de aspiración con un bajo nivel de ruido.

SUPERJET	A	A1	B	C	D	E	F	G	H	I	L	M
DF4/DF4R/ THERMALCUT	930	-	1120	1610	1915	1015	1210	2085	2043	866	838	433
DF6/ THERMALCUT	1100	-	1315	1805	2130	1190	1210	2260	2358	1038	840	553
DF9/ THERMALCUT	-	1500	1495	1979	2354	-	1293	2540	2532	1293	980	553



- Plenum insonorizzato.
- Soundproof plenum.
- Plenum insonorisé.
- Schalldämmhaube.
- Plenum insonorizado.

- Quadro elettrico per DF4 e DF6 (standard solo nel DF9).
- Electric control board for DF4 and DF6 (standard only in DF9).
- Armoire électrique pour DF4 et DF6 (standard seulement dans DF9).
- Schaltschrank für DF4 und DF6 (standard nur in DF9).
- Tablero eléctrico para DF4 y DF6 (standard sólo en DF9).

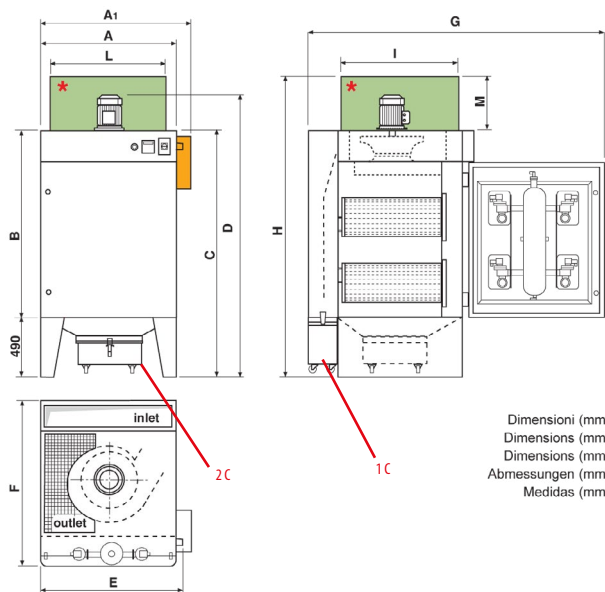

Dimensioni (mm)  
Dimensions (mm)  
Dimensions (mm)  
Abmessungen (mm)  
Medidas (mm)

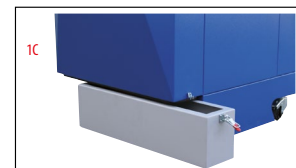

- 1C
- Cassetto di raccolta polveri pesanti.
  - Heavy dusts collection drawer.
  - Tiroir pour la collecte des poussières lourdes.
  - Schublade für die Sammlung von schwerere Staube.
  - Cajón recupero polvo pesado.



- 2C
- Cassetto di raccolta polveri filtrate fini.
  - Filtered dusts collection drawer.
  - Tiroir pour la collecte des poussières fines et filtrées.
  - Schublade für die Sammlung von feine und gefilterte Staube.
  - Cajón recupero polvo filtrado fino.



**IFA/BGIA-PTFE/MEMBRANE**

cod. SUPERJET-DF-CART/MEMBRANE  
Ø325 - H750 mm (B)

- Cartucce filtranti.
- Filtering cartridges.
- Cartouches filtrantes.
- Filterpatronen.
- Cartuchos filtrantes.
- Poliestere-membrana teflon
- Polyester-teflon membrane
- Polyester-membrane de teflon
- Polyester-ptfe- membran
- Poliéster-membrane de teflon

## M PES

cod. SUPERJET-DF-CART/MPES cod. SUPERJET-DF-CART/NANOTECH  
Ø325 - H750 mm (A) Ø325 - H660 mm (C)

- Cartuccia in Poliestere.
- Polyester cartridges.
- Cartouches Polyester.
- Polyesterpatronen.
- Cartuchos filtrantes.
- Cellulosa con nanofibre
- Cellulose with nanofibers
- Cellulose avec nanofibres
- Zellulose mit nanofaser
- Celulosa con nanofibras

# SUPERJET-DF



- Manometro / Presa pentapolare.
- Pressure switch / 5 Pins plug.
- Manomètre / Prise a 5 broches male.
- Manometer / 5-Poliger industriestecker.
- Manómetro / Enchufe pentapolar.



- cod. SUPERJET-FE
- Raccordo di ingresso.
  - Inlet connection.
  - Raccord d'entrée.
  - Übergangsstück saugseitig.
  - Cambio de sección de ingreso.

## OPTIONAL

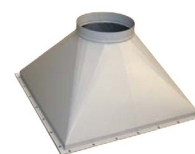
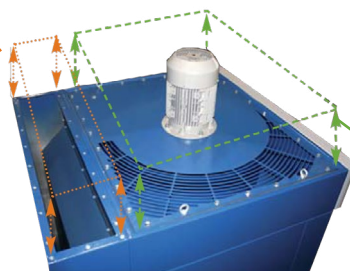

- cod. SUPERJET-FU
- Uscita dell'aria.
  - Air outlet.
  - Sortie d'air.
  - Ausblas.
  - Salida del aire.

- cod. PLUEMUN-INS
- Con rete.
  - With net.
  - Avec grille.
  - Mit schutzgitter.
  - Con red.

- cod. PLUEMUN-CA
- Con carboni attivi.
  - With activated carbons.
  - Avec charbons actif.
  - Mit aktivkohle.
  - On carbon activo.

- cod. PLUEMUN-FA
- Con filtro assoluto.
  - With hepa filter.
  - Avec filtre absolu.
  - Mit absolutfilter.
  - Con filtro absoluto.

## PLENUM INSONORIZZATO



Sistema automatico di pulizia ad aria compressa - Pneumatic cleaning automatic system (with compressed air) - Système automatique de décolmattage a air comprimé - Einer automatische Druckluftabreinigung - Sistema de limpieza por medio de aire comprimido



### SUPERJET-DF4



### SUPERJET-DF6



### SUPERJET-DF9

Dettagli tecnici - Technical details - Données techniques - Technische Daten - Datos Técnicos

Model	m <sup>3</sup> /h max	c.f.m.	%	m <sup>2</sup>	Kg	Lbs	V	phases	CART	Hz	cert	HP	KW	db
SUPERJET-DF4	2200	1298	99,99	37	380	836	230/400	3P+N+T	4 (A)	50/ 60 on request	CE	3	2,2	78
SUPERJET-DF430	3000	1770	99,99	48	385	847	230/400	3P+N+T	4 (A)	50/ 60 on request	CE	4	3	78
SUPERJET-DF4 THERMALCUT-N	2000	1180	-	84	460	1012	230/400	3P+N+T	4 (C)	50/ 60 on request	CE	3	2,2	77
SUPERJET-DF4 THERMALCUT-M	2000	1180	-	48	460	1012	230/400	3P+N+T	4 (B)	50/ 60 on request	CE	3	2,2	77
SUPERJET-DF6	4000	2360	99,99	72	470	1034	400/690	3P+N+T	6 (A)	50/ 60 on request	CE	5,5	4	81
SUPERJET-DF6 THERMALCUT-N	2500	2360	-	84	550	1240	230/400	3P+N+T	4 (C)	50/ 60 on request	CE	4	3	75
SUPERJET-DF6 THERMALCUT-M	2500	2360	-	48	550	1240	230/400	3P+N+T	4 (B)	50/ 60 on request	CE	4	3	75
SUPERJET-DF9	6500	3835	99,99	108	620	1364	400/690	3P+N+T	9 (A)	50/ 60 on request	CE	10	7,5	85
SUPERJET-DF9 THERMALCUT-N	3500	3835	-	126	752	1654	400/690	3P+N+T	6 (C)	50/ 60 on request	CE	5,5	4	79
SUPERJET-DF9 THERMALCUT-M	3500	3835	-	72	752	1654	400/690	3P+N+T	6 (B)	50/ 60 on request	CE	5,5	4	79



# SUPERJET-DF9PLUS



Il nuovo filtro a cartucce orizzontali SUPERJET-DF trova applicazione nell'aspirazione e filtrazione di fumi di saldatura, polveri grossolane e fini, trucioli in modesta quantità, polveri/fumi da taglio termico. Il gruppo è costituito da una precamera, dove la maggior parte delle polveri grossolane viene separata e si deposita nel primo cassetto di raccolta; il successivo labirinto e la sezione filtrante con cartucce ad alta efficienza provvedono alla filtrazione delle polveri residue. Il ventilatore ad alto rendimento, posto nella parte alta dell'unità, garantisce un'elevata capacità di aspirazione ed una bassa rumorosità.



The new SUPERJET-DF equipped with horizontal cartridges is suitable for suction and filtration of welding fumes, fine and coarse dusts as well as of small quantities of chips, dusts/fumes from thermal cutting. The filter unit consists of one pre chamber, where the most dusts are sorted out, falling then in the first collecting bin. The following labyrinth together with the high efficiency filtering cartridges and the second collecting bin complete the filtration of the remaining dusts. The high performance fan, placed just on the top of the unit, assures a high suction capacity and a low noise level.



Le nouveau filtre a cartouches horizontale SUPERJET-DF a été conçu pour l'aspiration et la filtration des fumées de soudure, poussières, de la plus fine à la plus grossière, certains types de copeaux en faible quantité, poussières et fumées de découpe laser. Le groupe est constitué d'une préchambre de décompression dans laquelle la majeure partie des polluants sont séparés et se déposent dans le premier caisson de récupération. La chicane qui suit et la partie filtration constituée de cartouches filtrantes à tres haute efficacité permettent une filtration des poussières résiduelles. Le motoventilateur a haut rendement, positionné dans la partie haute du groupe, fonctionne en dépression, assure une grande capacité d'aspiration et une niveau sonore particulièrement faible.



Das neue Filtergerät mit horizontalen Filterpatronen SUPERJET-DF findet die optimale Anwendung bei der Absaugung und Filtration von Schweißrauch, feinen und groben Stäuben, kleine Mengen an Späne, sowie Stäube und Rauch aus Laser- und Plasmaschneiden. Das Gerät besteht aus einer Vorkammer, bei welcher die groben Stäube bereits abgeschieden werden und sich in den ersten Behälter auf sammeln; das nachstehende Labyrinth und die Filterkammer mit Hochleistungspatronen gewährleisten die Filtration der Reststäube. Der im oberen Teil des Gerätes angeordnete Ventilator garantiert eine hohe Saugleistung und einen niedrige Lärmmission.



El nuevo filtro SUPERJET-DF con cartuchos horizontales, encuentra aplicación en la aspiración y filtración de humos de soldadura, polvos finos y gruesos en cantidades limitadas y polvos/humos procedentes de corte termico. El equipo está constituido por una pre cámara, donde se produce una primera pre-separación de la mayor parte de los polvos, que se depositan en el primer cajón de recolección. A seguir hay un laberinto y una sección de filtración con cartuchos de alta eficiencia donde se produce la filtración de los polvos residuos. Estos polvos residuos se depositan en el segundo cajón de recolección. El aire filtrado, atraviesa el ventilador de alto rendimiento, situado en la parte superior del filtro que garantiza una elevada capacidad de aspiración con un bajo nivel de ruido.

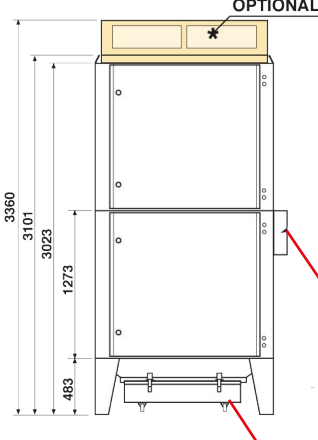
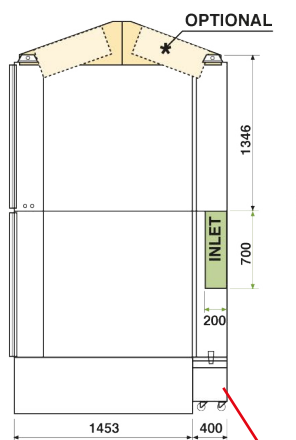

- Filtro assoluto OPTIONAL.
- HEPA filter OPTIONAL.
- Filtre absolu OPTIONAL.
- H13- Absolutfilter OPTIONAL.
- Filtro absoluto OPTIONAL.

- Gruppo predisposto per l'ingresso dell'aria sia sul lato destro sia sul lato sinistro.
- Air inlet right or left.
- Groupe prédisposé pour l'entrée de l'air aussi bien sur le coté droit que sur le coté gauche.
- Filtereintritt sowohl auf der linken Seite, als auch auf der rechten Seite.
- Opcion entrada aire lado derecho o izquierdo.



- Quadro elettrico.
- Electric control board.
- Armoire électrique.
- Schaltschrank.
- Tablero eléctrico.

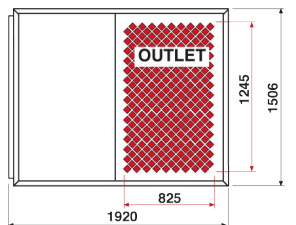

Dimensioni (mm)  
Dimensions (mm)  
Dimensions (mm)  
Abmessungen (mm)  
Medidas (mm)

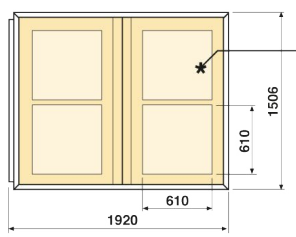

OPTIONAL



- Cassetto di raccolta polveri pesanti.
- Heavy dusts collection drawer.
- Tiroir pour la collecte des poussières lourdes.
- Schublade für die Sammlung von schwerere Staub.
- Cajon recupero polvo pesado.



- Cassetto di raccolta polveri filtrate fini.
- Filtered dusts collection drawer.
- Tiroir pour la collecte des poussières fines et filtrées.
- Schublade für die Sammlung von feine und gefilterte Staube.
- Cajon recupero polvo filtrado fino.

# SUPERJET-DF9PLUS



## filtration process

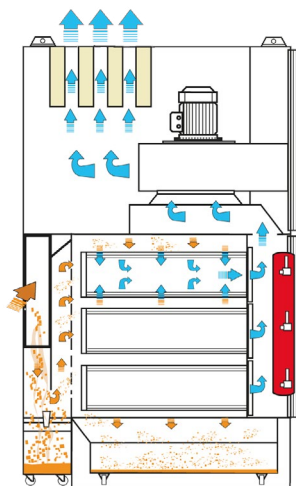

▲ ARIA INQUINATA  
AIR POLLUE  
POLLUTED AIR  
SCHMUTZLUFT  
AIRE CONTAMINADO

▲ ARIA FILTRATA  
AIR FILTRÉE  
CLEAN AIR  
REINLUFT  
AIRE FILTRADO

■ ARIA COMPRESSA  
AIR COMPRIMÉ  
COMPRESSED AIR  
DRUCKLUFT  
AIRE COMPRIMIDO



### M PES

cod. SUPERJET-DF-PLUS-CART/MPES  
Ø325 - H1200 mm  
-Cartuccia in Poliestere.  
-Polyester cartridges.  
-Cartouches Polyester.  
-Polyesterpatronen  
-Cartuchos filtrantes.

### NANOTECH

cod. SUPERJET-DF-PLUS-CART/NANOTECH  
Ø325 - H1200 mm  
-Cellulosa con nanofibres  
-Cellulose with nanofibres  
-Cellulose avec nanofibres  
-Zellulose mit nanofaser  
-Celulosa con nanofibras

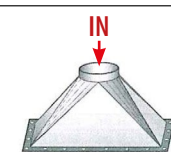

cod. SUPERJET-FE  
-Raccordo di ingresso.  
-Inlet connection.  
-Raccord d'entrée.  
-Übergangsstück saugseitig.  
-Cambio de sección de ingreso.

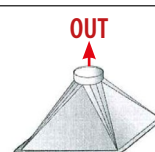

cod. SUPERJET-FU  
-Uscita dell'aria.  
-Air outlet.  
-Sortie d'air.  
-Ausblas.  
-Salida del aire.

Ø INLET/OUTLET ON REQUEST

### MEMBRANE

cod. SUPERJET-DF-PLUS-CART/ME-MEMBRANE  
Ø325 - H1200 mm  
-Membrana teflon  
-Teflon membrane  
-Membrane de teflon  
-Membran  
-Membrane de teflon

Sistema automatico di pulizia ad aria compressa - Pneumatic cleaning automatic system (with compressed air)  
- Système automatique de décolmattage a air comprimé - Einer automatischen Druckluftabreinigung - Sistema de limpieza por medio de aire comprimido

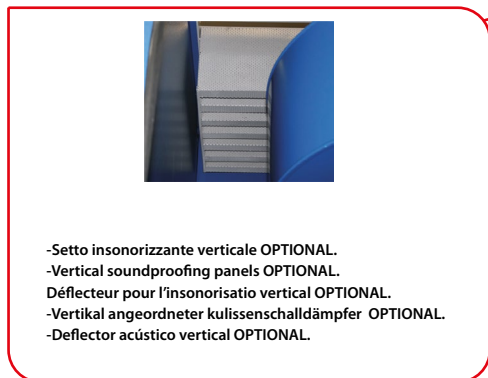

-Setto insonorizzante verticale OPTIONAL.  
-Vertical soundproofing panels OPTIONAL.  
Déflecteur pour l'insonorisatio vertical OPTIONAL.  
-Vertikal angeordneter kulissenschalldämpfer OPTIONAL.  
-Deflector acústico vertical OPTIONAL.



## SUPERJET-DF9PLUS

Dettagli tecnici - Technical details - Données techniques - Technische Daten - Datos Técnicos

Model	m <sup>3</sup> /h max	c.f.m.	%	m <sup>2</sup>	Kg	Lbs	V	phases	CART	Hz	cert	HP	KW
SUPERJET-DF9PLUS11	8000	4710	99,99	189	1450	3190	400	3P+N+T	9	50	CE	15	11
SUPERJET-DF9PLUS15	11000	6490	99,99	189	1500	3300	400	3P+N+T	9	50	CE	20	15



# SYSTEM CENTRALIZED SUPERJET

**SUPERJET-DF4**

	20 mt Tot (compreso Camino espulsione)	1/2 Contemporaneità
	20 mt Tot (including Chimney expulsion)	1/2 Contemporary
	20 mt Tot (y compris l'expulsion Cheminée)	1/2 Contemporaine
	20 mt Tot (wozu auch die Ausweisung Kamin)	1/2 Zeitgenössischen
	20 mt Tot (incluyendo la expulsión Chimenea)	1/2 Contemporaneidad

**SUPERJET-DF4R**

	20/30 mt Tot (compreso Camino espulsione)	2/3 Contemporaneità
	20/30 mt Tot (including Chimney expulsion)	2/3 Contemporary
	20/30 mt Tot (y compris l'expulsion Cheminée)	2/3 Contemporaine
	20/30 mt Tot (wozu auch die Ausweisung Kamin)	2/3 Zeitgenössischen
	20/30 mt Tot (incluyendo la expulsión Chimenea)	2/3 Contemporaneidad

**SUPERJET-DF6**

	30/35 mt Tot (compreso Camino espulsione)	3/3 Contemporaneità
	30/35 mt Tot (including Chimney expulsion)	3/3 Contemporary
	30/35 mt Tot (y compris l'expulsion Cheminée)	3/3 Contemporaine
	30/35 mt Tot (wozu auch die Ausweisung Kamin)	3/3 Zeitgenössischen
	30/35 mt Tot (incluyendo la expulsión Chimenea)	3/3 Contemporaneidad

# SYSTEM CENTRALIZED SUPERJET



**SUPERJET-DF9**

	40/45 mt Tot (compreso Camino espulsione)	4/4 Contemporaneità
	40/45 mt Tot (including Chimney expulsion)	4/4 Contemporary
	40/45 mt Tot (y compris l'expulsion Cheminée)	4/4 Contemporaine
	40/45 mt Tot (wozu auch die Ausweisung Kamin)	4/4 Zeitgenössischen
	40/45 mt Tot (incluyendo la expulsión Chimenea)	4/4 Contemporaneidad

**SUPERJET-DF9PLUS11**

	50/60 mt Tot (compreso Camino espulsione)	5/6 Contemporaneità
	50/60 mt Tot (including Chimney expulsion)	5/6 Contemporary
	50/60 mt Tot (y compris l'expulsion Cheminée)	5/6 Contemporaine
	50/60 mt Tot (wozu auch die Ausweisung Kamin)	5/6 Zeitgenössischen
	50/60 mt Tot (incluyendo la expulsión Chimenea)	5/6 Contemporaneidad

**SUPERJET-DF9PLUS15**

	60/70 mt Tot (compreso Camino espulsione)	6/7 Contemporaneità
	60/70 mt Tot (including Chimney expulsion)	6/7 Contemporary
	60/70 mt Tot (y compris l'expulsion Cheminée)	6/7 Contemporaine
	60/70 mt Tot (wozu auch die Ausweisung Kamin)	6/7 Zeitgenössischen
	60/70 mt Tot (incluyendo la expulsión Chimenea)	6/7 Contemporaneidad



Unità filtrante ad azione meccanica per abbattimento fumi di saldatura. Equipaggiato con prefiltro metallico antiscintilla, 2 celle filtranti in poliestere ad efficienza crescente e cella di carboni attivi per deodorare i fumi filtrati. Ideale per impianti con reintegro fumi in ambiente di lavoro, STARFILTER è disponibile in 2 modelli da 2.000 e 4.000 m<sup>3</sup>/h.



Mechanical Filtering unit for cleaning welding fumes. Equipped with metallic anti-spark pre-filter, 2 incremental efficiency polyester filtering cells and an activated carbon cell for deodorising filtered fumes. Ideal for systems where fumes are recycled into the working area, STARFILTER is available in two models: 2.000 and 4.000 m<sup>3</sup>/h.



Unité mécanique pour la filtration des fumées de soudure. Équipé d'un préfiltre métallique anti-étincelles, de 2 cellules filtrantes en polyester à efficacité progressive et de cellule à charbons actifs pour désodoriser les fumées filtrées. Idéal pour installations à recyclage des fumées en atmosphère de travail, STARFILTER existe en 2 modèles de 2.000 et 4.000 m<sup>3</sup>/h.



Mechanische wirkender Filtereinheit für das Abscheiden von Schweißrauch. Ausgestattet mit Funkenlöcher-Vorfilter aus Metall, 2 Filterzellen aus progressiv aufgebautem Polyester und einer Aktivkohlezelle zur Geruchsverbesserung der gefilterten Rauche. Ideal für Anlagen, bei denen der Rauch in die Arbeitsumgebung zurückgeführt wird. STARFILTER ist in 2 Modellen - 2.000 und 4.000 m<sup>3</sup>/h - erhältlich.



Maquinas filtrantes fijas con filtro ad accion mecanica para eliminar los humos de soldadura. Equipado con prefiltro metálico antichispa, 2 cámaras filtrantes de poliéster de eficacia creciente y cámara de carbón activo para desodorizar los humos filtrados. Ideal para sistemas con evacuación de humos en el ambiente de trabajo. STARFILTER está disponible en 2 modelos de 2.000 y 4.000 m<sup>3</sup>/h.

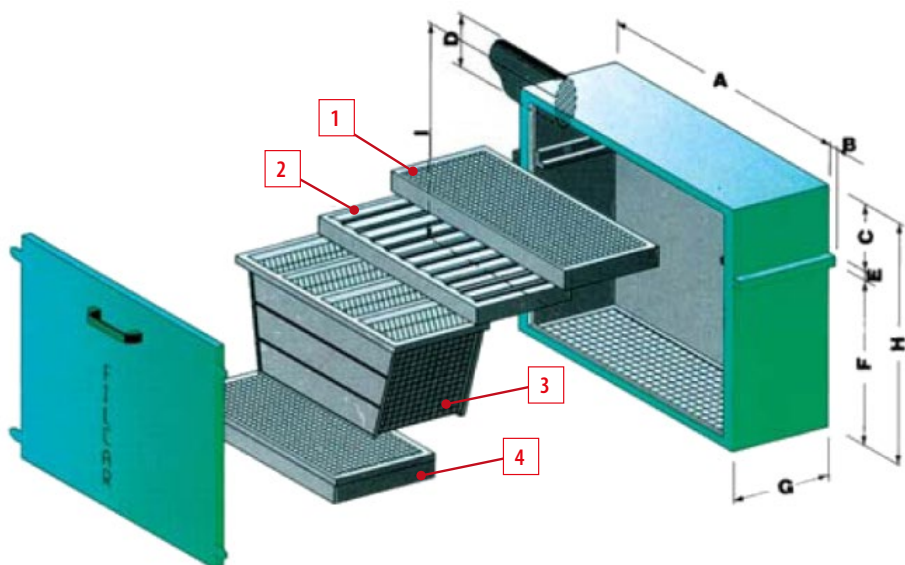

**1 FIREFILTER**  
(cod. STAR2000-RIPM)

**2 PREFILTER**  
(cod. STAR2000-RIPS)

**3 SMOKEFILTER**  
(cod. STAR-2000-RIF)

**4 CARBONFILTER**  
(cod. STAR2000-CONT)

**STAR-2000**

A	B	C	D	E	F	G	H	I
700	45	320	200	55	445	310	820	690

Dettagli tecnici - Technical details - Données techniques - Technische Daten - Datos Técnicos

Model	m <sup>3</sup> /h	c.f.m.	mm H <sub>2</sub> O	Pa	%	Kg	Lbs	Carb. Kg	Carb. Lbs
<b>STARFILTER-2000</b>	2000	1176	75	750	95	55	121	8	17,6



# STARFILTER

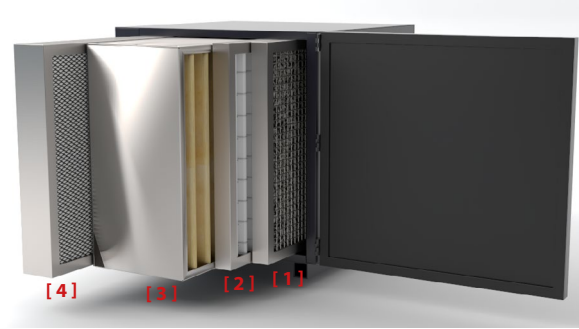

STAR4000-RIPM-NG [1]	FIREFILTER Filtro metallico - FIREFILTER Metal Filter - FIREFILTER Filtres en paille metallique - FIREFILTER Metallfilter - FIREFILTER Filtro metálico
STAR4000-RIPS-NG [2]	PREFILTER Filtro sintetico - PREFILTER Synthetic filter - PREFILTER filtre synthétique - PREFILTER Synthetikfilter - PREFILTER Filtro sintético
STAR-4000-RIF-NG [3]	SMOKEFILTER Filtro ad alta efficienza - SMOKEFILTER High efficiency filter - SMOKEFILTER Filtre à haute efficacité - SMOKEFILTER HochleistungsfILTER - SMOKEFILTER Filtro de alta eficiencia
STAR4000-CONT-NG [4]	CARBOFILTER Contenitore completo di 16 Kg. carboni attivi - CARBOFILTER Container complete with 16 Kg. active carbon - CARBOFILTER Réceptier avec 16 Kg. charbon actif - CARBOFILTER Behälter komplett mit 16 Kg. Aktivkohle - CARBOFILTER Recipiente de carbón activado de 16 Kg. carbón activado

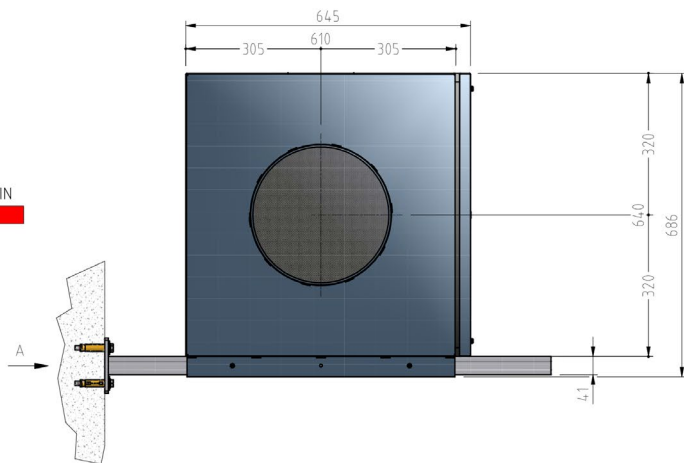
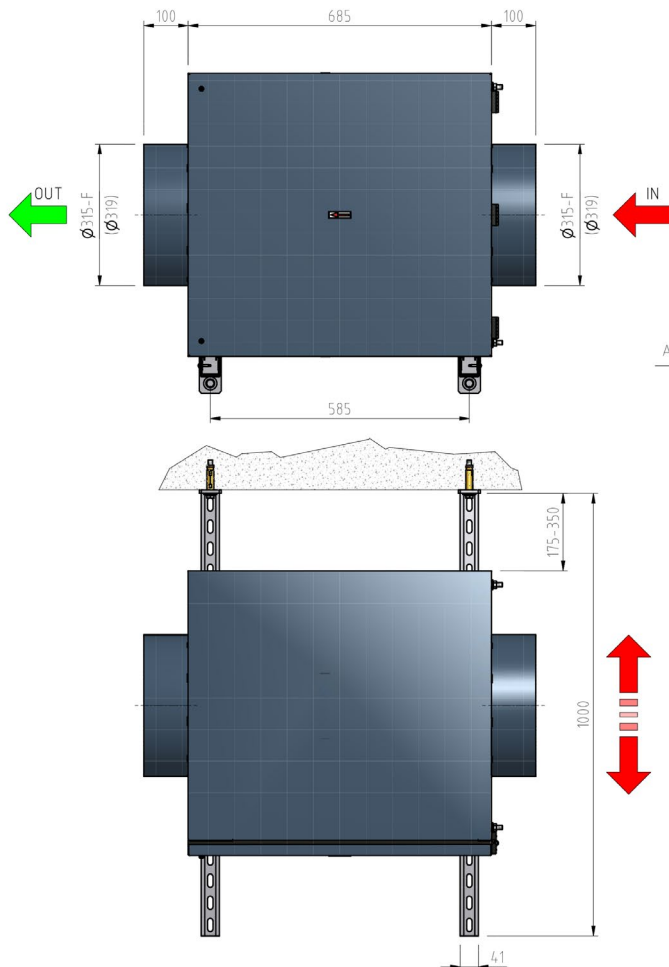

Dettagli tecnici - Technical details - Données techniques - Technische Daten - Datos Técnicos

Model	m <sup>3</sup> /h	c.f.m.	mm H <sub>2</sub> O	Pa	%	Kg	Lbs	Carb. Kg	Carb. Lbs
STARFILTER-NG-4000	4000	2352	85	850	95	90	199	16	35,2



 Filtro modulare a tasche di poliestere per la filtrazione di fumi di saldatura. La combinazione del modello FILTER con il modello CARBON permette di filtrazione e deodorare dei fumi su impianti con portate fino a 27.000 m<sup>3</sup>/h.

 Modular polyester pocket filter for filtering welding fumes. The combination of the FILTER and CARBON models can be used to filter and deodorise fumes in systems with a capacity of up to 27.000 m<sup>3</sup>/h.

 Filtre modulaire à poches en polyester pour filtration de fumées de soudure. La combinaison du modèle FILTER au modèle CARBON permet de filtrer et de désodoriser des fumées sur des installations à des débits jusqu'à 27.000 m<sup>3</sup>/h.

 Modularer Polyester-Taschenfilter für das Filtern von Schweißrauch. Die Kombination des Modells FILTER mit dem Modell CARBON ermöglicht das Filtern und die Geruchsverbesserung von Rauchen an Anlagen mit Leistung bis 27.000 m<sup>3</sup>/h.

 Filtro modular de compartimentos en poliéster para filtrar humos de soldadura. Combinando los modelos FILTER y CARBON es posible filtrar y desodorizar los humos de sistemas con caudales de hasta 27.000 m<sup>3</sup>/h.

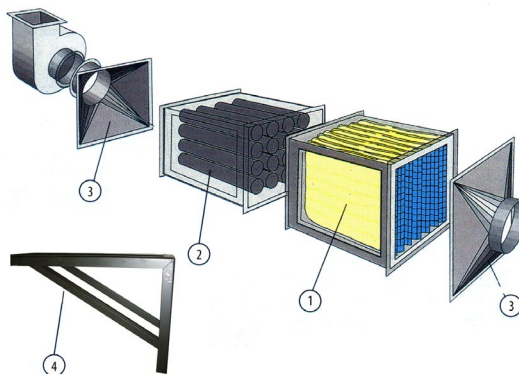
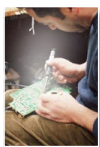

N	Model
1	FILTER
2	CARBON
3	FEU*
4	ME-750-1000

\* Scegliere il Ø di uscita  
 \* Choose the outlet diam.  
 \* Choisir le Ø de sortie  
 \* Bitte Ausblas DN wählen  
 \* Indicar diámetro de salida

# FILTER-CARBON

**FILTER**

**CARBON**

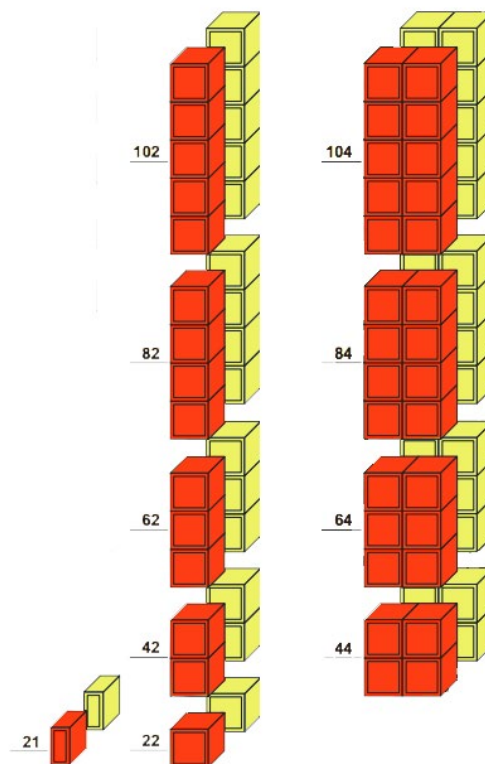
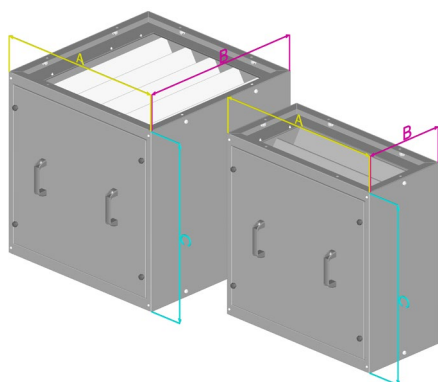

Dettagli tecnici - Technical details - Données techniques - Technishe Daten - Datos Técnicos

FILTER	m <sup>3</sup> /h	c.f.m.	Tot Kg	Lbs	A	B	C		Cod.
FILTER-21	1500	882	25	55	700	350	700	Ricambi - Spare parts - Pièces détachées - Ersatzteile - Refacciones	1 x PF-287 - 1 x FIT-287
FILTER-22	3000	1764	42	92	700	700	700		1 x PF-590 - 1 x FIT-590
FILTER-42	6000	3529	84	185	1400	700	700		2 x PF-590 - 2 x FIT-590
FILTER-44	12000	7058	168	370	1400	1400	700		4 x PF-590 - 4 x FIT-590
FILTER-62	9000	5292	126	277	2100	700	700		3 x PF-590 - 3 x FIT-590
FILTER-64	18000	10588	252	554,4	2100	1400	700		6 x PF-590 - 6 x FIT-590

Cod. FILTRI
PF-287 PREFILTER 700 x 350
PF-590 PREFILTER 700 x 700
FIT-287 FILTER 700 x 350
FIT-590 FILTER 700 x 700

**FILTER**



95% FILTRATION EFFICIENCY

CARBON	Carb. Kg	Tot Kg	Tot. Lbs	A	B	C		Cod.
CARBON-21	20	48	105	700	350	700	Ricambi - Spare parts - Pièces détachées - Ersatzteile - Refacciones	2 x CARBON-RIS 10 Kg
CARBON-22	40	88	194	700	700	700		4 x CARBON-RIS 10 Kg
CARBON-42	80	176	387	1400	700	700		8 x CARBON-RIS 10 Kg
CARBON-44	160	352	775	1400	1400	700		16 x CARBON-RIS 10 Kg
CARBON-62	120	264	509	2100	700	700		12 x CARBON-RIS 10 Kg
CARBON-64	240	528	1162	2100	1400	700		24 x CARBON-RIS 10 Kg

Cod. CARTUCCIA
CARBON-CARTU
CARBON-RIS 10 Kg

**CARBON**







 **Filtro modulare a cartucce (IFA - BIA - M PES) per la depurazione di fumi e polveri derivanti da processi di saldatura o taglio. Studiato per impianti centralizzati anche di portata elevata dispone di sistema di pulizia automatica ad aria compressa per mezzo di programmatore ciclico con depressostato differenziale. Portata max 31.000 m<sup>3</sup>/h.**

 **Modular cartridge filter (IFA - BIA - M PES category) suitable for the extraction and filtration of fumes and dusts produced by welding and cutting procedures. It is suitable for centralized systems requiring high airflows. It is equipped with automatic and pneumatic cyclic cleaning programmer with differential pressure gauge. Max airflow 31.000 m<sup>3</sup>/h.**

 **Filtre modulaire à cartouches (IFA - BIA - M PES) pour le dépolluissage des fumées et poussières dérivantes de procédés de soudage ou de coupage. Étudié pour des installations centralisées même à des débits élevés, le filtre dispose d'un système de décolmatage par jet d'air comprimé programmable avec pressostat différentiel. Débit maximum: 31.000 m<sup>3</sup>/h.**

 **Modulpatronenfilter (IFA - BIA - M PES) fuer Rauch- und Staubreinigung; bestimmt fuer Rauch und Staub, die von Schweiß- Schnittdarbeit verursacht sind. Fuer zentralisierte- mit Hochfoerderleistungsanlage geplant, mit Druckluftautomatischesreinigungssystem der durch ein zyklische Programm mit differenzial Druckschalter funktioniert. Maximale Leistung bis 31.000 m<sup>3</sup>/St.**

 **Unidad filtro-aspirante con cartucho (IFA - BIA - M PES) para la depuración de humo y polvo producidos durante procesos de soldadura y corte. Desarrollado para instalaciones centralizadas también de grandes caudales, lleva un sistema de limpieza automática con aire comprimido por medio de un programador cíclico con depressostato diferencial. Caudal max 31.000 m<sup>3</sup>/h.**

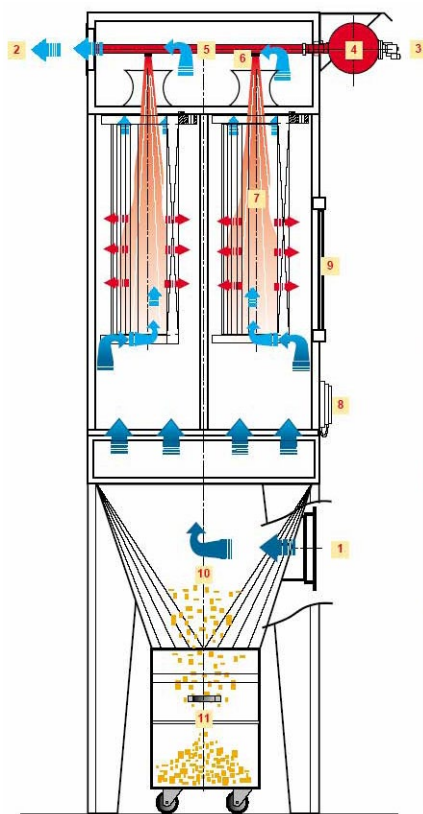
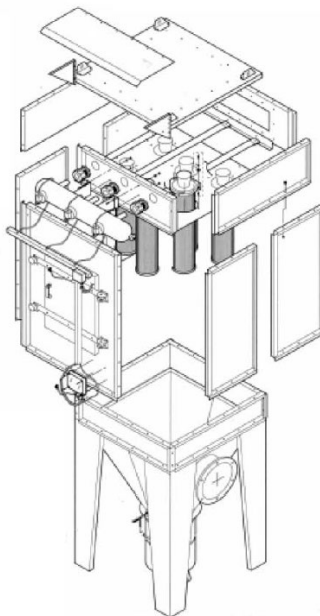

**FILTERJET-30/40/60/80**

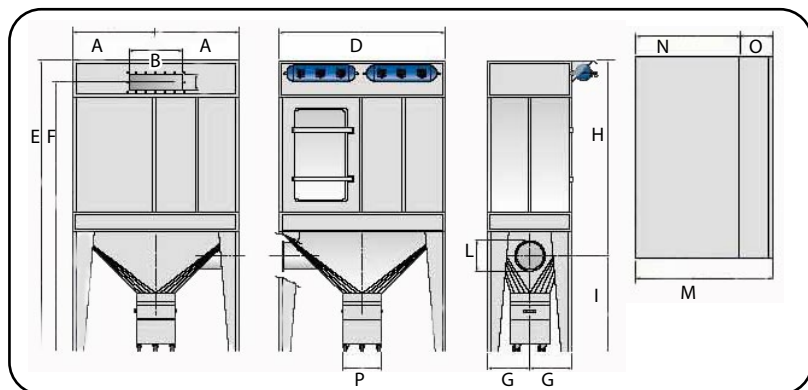

**FILTERJET-90**

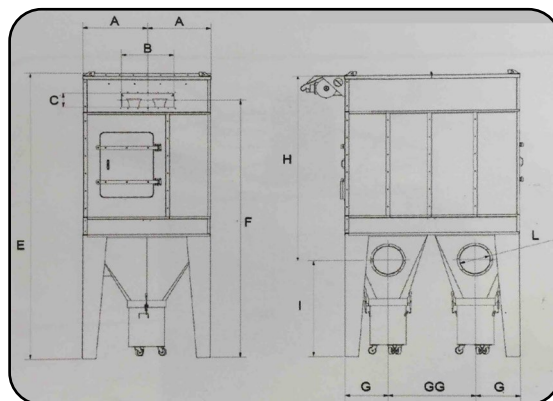

**FILTERJET-120/210**

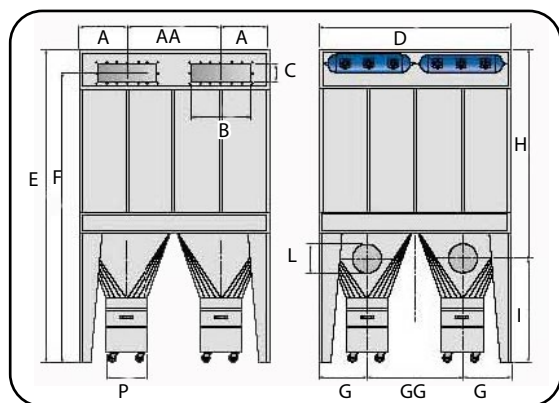

**FILTERJET-310**

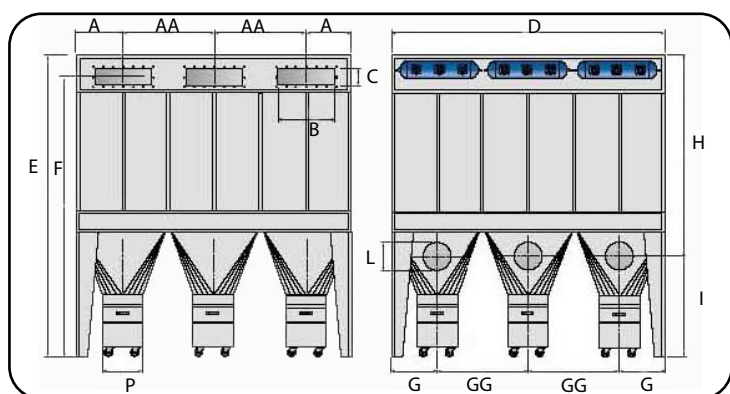

**cod. SUPERJET-FE**  
 -Raccordo di ingresso.  
 -Inlet connection.  
 -Raccord d'entrée.  
 -Übergangsstück saugseitig.  
 -Cambio de sección de ingreso.

**cod. SUPERJET-FU**  
 -Uscita dell'aria.  
 -Air outlet.  
 -Sortie d'air.  
 -Ausblas.  
 -Salida del aire.

Ø INLET/OUTLET ON REQUEST



-Pulizia automatica  
 -Automatic Cleaning  
 -Décolmatage Automatique  
 -Automatischesreinigungssystem  
 -Limpieza Automática



**cod. FILTERJET/C07 - Ø325X175X700**  
 IFA -BGIA-M-PES

**cod. FILTERJET/C10 - Ø325X175X1000**  
 IFA -BGIA-M-PES

**Dettagli tecnici - Technical details - Données techniques - Technishe Daten - Datos Técnicos**

Model	A	AA	B	C	D	E	F	G	GG	H	I	L	M	N	O	P	m <sup>3</sup> /h	N. Cart	Ø CART	m <sup>2</sup>	Kg	Lbs
<b>FILTERJET-30</b>	575	-	700	200	1150	3515	3170	575	-	2145	1370	400	1550	1150	400	500	3600	6	Ø325x700	65	450	990
<b>FILTERJET-40</b>	575	-	700	200	1150	4015	3670	575	-	2645	1370	400	1550	1150	400	500	5200	6	Ø325x1000	94	580	1276
<b>FILTERJET-60</b>	850	-	700	200	1700	4015	3670	575	-	2615	1400	400	1550	1150	400	500	6900	8	Ø325x1000	125	840	1848
<b>FILTERJET-80</b>	1150	-	700	200	2300	4015	3670	575	-	2615	1400	400	1550	1150	400	500	10300	12	Ø325x1000	188	1100	2420
<b>FILTERJET-90</b>	820	-	700	200	2300	4015	3670	570	1160	2615	1400	400	2100	1700	400	500	13500	16	Ø325x1000	250	1650	3630
<b>FILTERJET-120</b>	630	1100	700	200	3460	4015	3670	570	1160	2645	1370	400	1550	1150	400	500	15500	18	Ø325x1000	282	1820	4004
<b>FILTERJET-210</b>	600	1100	700	200	2300	4015	3670	570	1160	2615	1400	400	2700	2300	400	500	20700	24	Ø325x1000	376	2200	4840
<b>FILTERJET-310</b>	630	1100	700	200	3460	4015	3670	570	1160	2615	1400	400	2700	2300	400	500	31000	36	Ø325x1000	564	3200	7040



Gruppo filtro-aspirante per nebbie oleose completo di elettroaspiratore. Grazie alla forza centrifuga del prefiltro elicoidale viene separata la quasi totalità delle particelle oleose. Per eliminare eventuali impurità residue l'aria passa attraverso un filtro a tasche a grande superficie filtrante. Portata max 3.600 m<sup>3</sup>/h. Disponibile in versione carrellata con 1 bracci Ø150 L 3 mt o fisso per impianti centralizzati OIL-GAMM-2M.



Filtering unit equipped with fan for oil mists. The biggest part of the oil particles are separated thanks to centrifugal effect of the helical prefilter. The possible remaining impurities in the air are collected by a pocket filter with wide filtering surface. Max airflow 3.600 m<sup>3</sup>/h. Available as trolley version with one arm Ø150 L 3 mt or stationary as centralized projects OIL-GAMM-2M.



Groupe aspirant et filtrant pour brouillard d'huile. Grâce au ventilateur et à la force centrifuge dans le préfiltre, les particules huileuses sont séparées de l'air. Les impuretés restantes sont filtrées à travers un filtre à poche et les substances liquides sont récupérées dans un récipient, Débit d'aspiration maximum : 3.600 m<sup>3</sup>/h. Disponible dans la version avec chariot et 1 bras Ø150 de 3 mt. ou dans la version fixe pour systèmes centralisés OIL-GAMM-2M.



Filter und Absaugungseinheit fuer Oelnebel ausgestattet mit Ventilator. Dank der Zentrifugalkraft der Spiralvorfilter werden fast alle Oelpartikeln getrennt. Um eventuelle Unreinheiten zu vermeiden, dann wird das Luft durch ein Taschenfilter mit hoehe Filterflaeche filtriert. Foerderleistungen 3.600 M<sup>3</sup>/St. Erhältlich in der Rädern Version mit ein Arme Ø150 von 3 mt., oder in der feste Version fuer zentralisierte Systeme OIL-GAMM-2M.



Grupo filtro-aspirante para neblina de aceite completo de electroaspirador. Gracias a la fuerza centrifuga del prefiltro elicoidal, se separa casi la totalidad de las partículas aceitosas. Para eliminar eventuales impurezas residuales, el aire pasa a través de un filtro a bandeja con grande superficie filtrante. Caudal max 3.600 m<sup>3</sup>/h. Disponible en version sobre ruedas con 1 brazo Ø150 L 3 mt o fijo para estructuras centralizadas OIL-GAMM-2M.

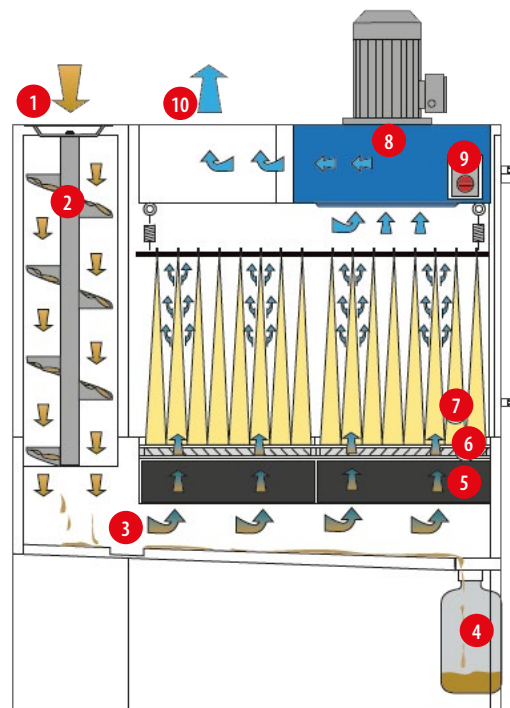

- 1 ENTRATA NEBBIE OLEOSE - OIL MIST AIR INLET - ARRIVÉE DES BROUILLARDS D'HUILE - SAUGUNG ÖLNEBEL - ENTRADA NUBES ACEITOSAS
- 2 SEPARATORE CENTRIFUGO - CENTRIFUGAL SEPARATOR - SÉPARATEUR CENTRIFUGE - ZENTRIFUGALSEPARATOR - SEPARADOR CENTRÍFUGO
- 3 TRAMOGGIA SCARICO OLIO - OIL DRAIN HOPPER - TRÉMIE D'ÉVACUATION DE L'HUILE - ÖLABLASS-TRICHTER - TOLVA DESCARGA DE ACEITE
- 4 BIDONE DI RACCOLTA OLIO - OIL COLLECTING TANK - BIDON DE RÉCUPÉRATION D'HUILE - SAMMELBEHÄLTER - BIDON DE RECOLECCIÓN DE ACEITE
- 5 SEPARATORE DI GOCC - DROP SEPARATOR - SÉPARATEUR DE GOUTTES - TROPFENABSCHIEDER - SEPARADOR DE GOTAS (OPTIONAL)
- 6 PREFILTRO IN PAGLIA METALLICA - WIRE METAL MESH PREFILTER - PRÉFILTRE EN PAILLE MÉTALLIQUE - VORFILTER AUS METALLSTROH - PREFILTRO EN PAJA METÁLICA
- 7 FILTRO A TASCHE - FILTRE À POCHE - POCKET FILTER - TASCHEFILTER - FILTRO DE BOLSILLOS
- 8 VENTILATORE - FAN - VENTILATEUR - VENTILATOR - VENTILADOR
- 9 INTERRUPTORE TERMICO A NORME CE - CE RULES THERMAL SWITCH - INTERRUPTEUR AUX NORMES CE - EIN/AUS SCHALTER - INTERRUPTOR TÉRMICO DE ACUERDO CON LAS NORMAS CE
- 10 USCITA ARIA FILTRATA - CLEAN AIR OUTLET - SORTIE D'AIR FILTRÉE - REINLUFT-AUSBLASSEITE - SALIDA AIRE FILTRADO

# OIL-GAMM



## OPTIONAL

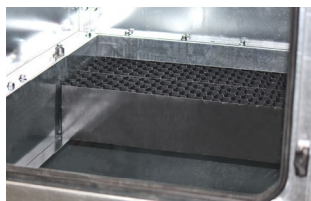

- cod.  
 -Separatore di gocce  
 -Drop separator  
 -Séparateur de gouttes  
 -Tropfenabscheider  
 -Separador de gotas



- cod.  
 -Sifone per scarico  
 -Siphon for discharge  
 -Siphon pour évacuation  
 -Syphon zum austrag  
 -Sifón de descarga



- cod.  
 -Pressostato differenziale con contatto pulito per segnalazione intasamento filtro su quadro elettrico  
 -Pressure switch for filter clogging alarm on control board  
 -Pressostat différentiel avec contact sec pour indication de l'encrassement des filtres, sur l'armoire électrique  
 -Differenzdruckmesser mit potentialfreien ausgang zur filter-sättigungsanzeige am schaltschrank  
 -Presostato diferencial completo de con-tacto limpio para la señalización de suciedad del filtro en el tablero eléctrico



- cod.  
 -Raccordo d'ingresso  
 -Inlet connection  
 -Raccord d'entree  
 -Übergangsstück saugseitig  
 -Cambio de sección de ingreso

CODE	A mm	B mm
OIL-GAMM-1	1892	1022
OIL-GAMM-2	1936	1022
OIL-GAMM-4	1970	1412
OIL-GAMM-2M	1936	1022

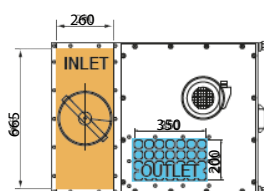
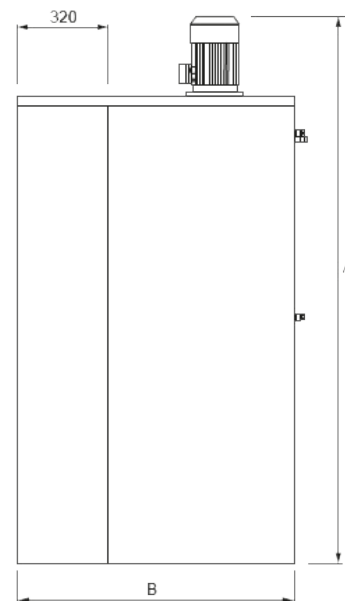
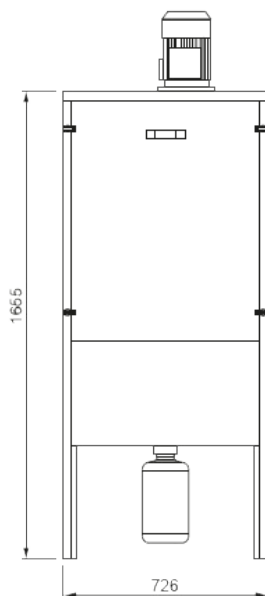

**OIL-GAMM-1**

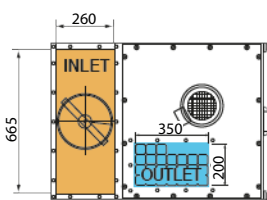

**OIL-GAMM-2/2M**

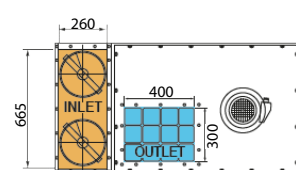

**OIL-GAMM-4**

## Dettagli tecnici - Technical details - Données techniques - Technische Daten - Datos Técnicos

Model	Kg	Lbs	HP	kW	R.P.M	dBA	V*	Hz	m <sup>3</sup> /h	c.f.m.	%	l	inlet Ø mm	outlet
OIL-GAMM-1	160	352	1	0,75	2800	74	230/400*	3 Ph 50 Hz	1315	776	99	5	on request	
OIL-GAMM-2	192	424	2	1,5	2800	76	230/400*	3 Ph 50 Hz	2530	1493	99	5		
OIL-GAMM-4	245	540	4	3	2800	83	230/400*	3 Ph 50 Hz	3600	2124	99	5		
OIL-GAMM-2M	192	424	2	1,5	2800	76	230/400*	3 Ph 50 Hz	2530	1493	99	5		

\* DISPONIBILE ANCHE MONOFASE 230V - MONOPHASE 230V VERSION AVAILABLE - DISPONIBLE EGALEMENT EN MONOPHASE 230V - AUCH EINFASIG VERFÜGBAR 230V - TAMBIÉN DISPONIBLE MONOFÁSICO 230 VOLTIOS



Il gruppo filtrante NOIL è stato concepito per purificare l'aria negli ambienti di lavoro ove si producono nebbie oleose e per recuperare l'olio consentendone il riciclo. Grazie all'impiego di un prefiltro in cellulosa e di un filtro in poliestere testati BIA USG, C, viene garantito un alto rendimento di captazione delle particelle oleose, il cui valore medio è pari al 98%. L'aria puricata viene quindi riciclata nell'ambiente di lavoro.



The NOIL filter unit has been made to purify the air in working premises, where oily fumes are produced and to recover the oil allowing the recycle of it. Thanks to the joint use of a BIA tested USG, C rated cellulose prefilter and polyester filter an high efficiency up to an average value of 98% in the capture of oil particles is guaranteed. The filtered air is then recycled in the work premises.



Le groupe NOIL a été conçu pour purifier l'air dans les milieux de travail où l'on produit des brouillards d'huile et permet la récupération de l'huile filtrée. Grâce à l'utilisation d'un filtre en cellulose et d'un filtre en polyester testés BIA USG, C on garanti une excellente captation des particules huileuses, dont la valeur moyenne est de 98%. On recycle par conséquent l'air purifié dans la zone de travail.



Das neue filtergerät wird in den räumen eingebaut, wo öl- und emulsionsnebel verursacht werden, um die luft zu reinigen und das gefilterte öl zurückzuerhalten. Die Anwendung eines besonderen Vorfilters aus zellulose und einer Polyester-Filterpatrone (Filterklasse BIA USG, C) garantiert einen durchschnittlichen Abscheidegrad vom 98%. Die gereinigte Luft wird danach im den Arbeitsraum rückgeführt.



El grupo de filtración NOIL ha sido creado tanto para purificar el aire en los ambientes de trabajo donde se producen neblinas oleosas como para recuperar el aceite filtrado permitiendo su reciclado. Gracias al uso de un pre-filtro de celulosa y de un filtro de poliéster, se garantiza un alto rendimiento de captación de las partículas oleosas, cuyo valor medio es equivalente al 98%. El aire purificado por consiguiente vuelve al ambiente de trabajo.

➔ ARIA INQUINATA - POLLUTED AIR - AIR POLLUÉ  
- KONTAMINIERTE LUFT - AIRE CONTAMINADO

➔ OLIO - OIL - HUILE - ÖL - ACEITE

➔ ARIA FILTRATA - CLEAN AIR - AIR FILTRÉ  
- REINLUFT - AIRE FILTRADO

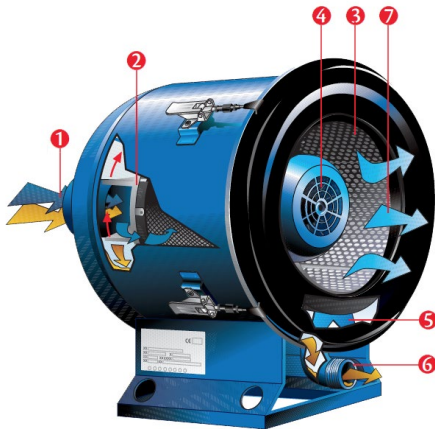

- 1 ENTRATA NEBBIE OLEOSE - OIL MIST AIR INLET - ARRIVÉE DES BROUILLARDS D'HUILE - SAUGUNG ÖLNEBEL - ENTRADA NUBES ACEITOSAS
- 2 VENTOLA - IMPELLER - TURBINE - LAUFRAD - TURBINA
- 3 CARTUCCIA FILTRANTE - FILTER CARTRIDGE - CARTOUCHE FILTRATE - FILTERPATRONE - CARTUCHO FILTRANTE
- 4 MOTORE ELETTRICO - ELETTRIC MOTOR - MOTEUR ELETRIQUE - MOTOR - MOTOR ELECTRICO
- 5 STAFFA SUPPORTO CARTUCCIA - CARTRIDGE HOLDING BRACKET - BRIDE SUPPORT CARTOUCHE - HALTERUNG PATRONE - SOSTEN DE CARTUCHO
- 6 SCARICO OLIO - OIL OUTLET - EVACUATION DE L'HUILE - ÖLABLAß - DESCARGA DE ACEITE
- 7 USCITA ARIA FILTRATA - CLEAN AIR OUTLET - SORTIE D'AIR FILTRÉ - AUSBLAS REINLUFT - SALIDA AIRE FILTRADO

## ESEMPI DI INSTALLAZIONI - INSTALLATION EXAMPLE - EXEMPLE D'INSTALLATION - EINSATZBEISPIELE - EJEMPLOS DE INSTALACIONES

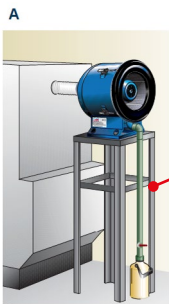

cod. NOIL-CAV

A) Installazione del gruppo NOIL su cavalletto.  
A) Stand support installation  
A) Installation du groupe NOIL sur un chevalet  
A) Aufstellung des NOIL auf einem Halter.  
A) Instalación sobre cavallette

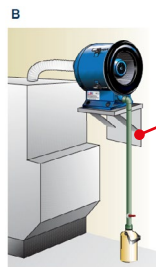

cod. NOIL-MENS

B) Installazione pensile.  
B) Installation on a wall mounted bracket  
B) Installation murale  
B) Aufstellung des NOIL auf Konsole. Ölentleerung in Plastik-Tank  
B) Instalación colgante



C) Installazione su supporto a colonna con scarico olio in vasca  
C) Installation on a column support  
C) Installation sur support à colonne  
C) Ölentleerung in die Sammelwanne  
C) Instalación con soporte a columna



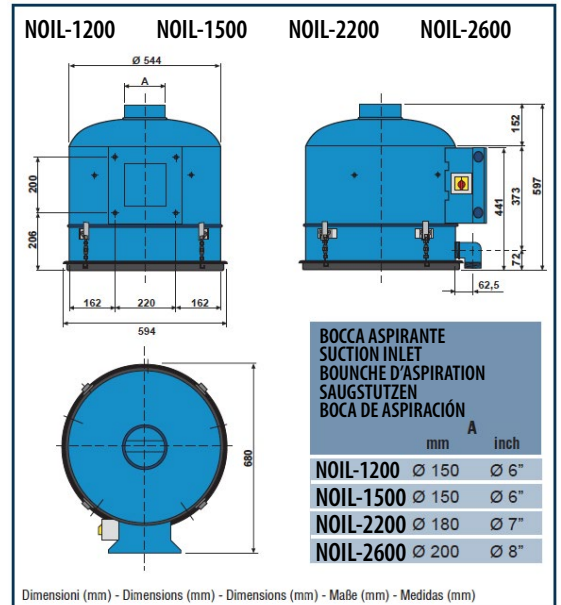
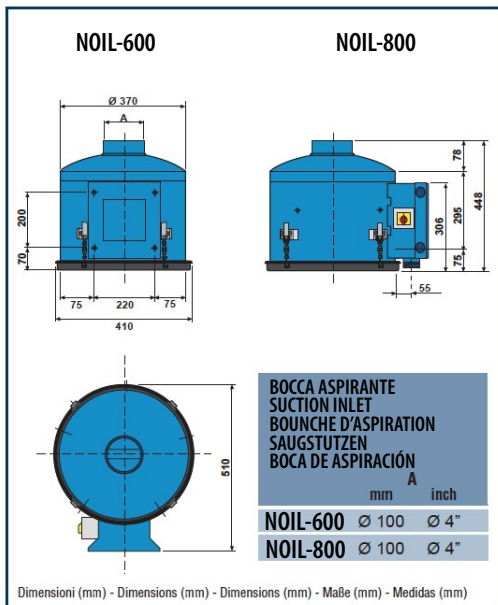

## Accessori - Accessories - Accessoires - Zubehör - Accesorios

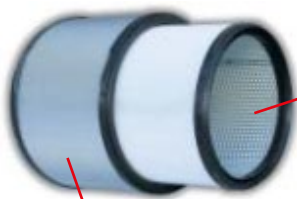

cod. NOIL-1-CA/POL - NOIL-2-CA-POL  
IFA/BGIA M-PES  
-Cartuccia in poliestere  
-Polyester cartridge  
-Cartouche filtrante en polyéster  
-Patronenfilter aus Polyester  
-Cartucho en poliéster

cod. NOIL-1-CA/CEL - NOIL-2-CA-CEL  
IFA/BGIA M-CEL  
-Cartuccia in cellulosa  
-Cellulose filter cartridge  
-Cartouche filtrante en cellulose  
-Patronenfilter aus Zellulose  
-Cartucho de celulosa

-Cartuccia in poliestere  
-Polyester cartridge  
-Cartouche filtrante en polyester  
-Filterpatrone aus polyester  
-Cartucho en poliéster



## Dettagli tecnici - Technical details - Données techniques - Technische Daten - Datos Técnicos

Model	Kg	Lbs	HP	kW	Hz	R.P.M	dBA	V	m <sup>3</sup> /h	c.f.m.	mmH <sub>2</sub> O	inlet Ø mm
<b>NOIL-600</b>	28	62	1	0,75	50	2900	68	230/400	600	350	50	100
<b>NOIL-800</b>	29	64	1	0,75	50	2900	72	230/400	800	470	50	100
<b>NOIL-1200</b>	55	122	2	1,5	50	2900	74	230/400	1200	700	50	150
<b>NOIL-1500</b>	56	124	2	1,5	50	2900	75	230/400	1500	880	50	150
<b>NOIL-2200</b>	55	122	2	1,5	50	2900	75	230/400	2200	1290	50	180
<b>NOIL-2600</b>	56	124	2	1,5	50	2900	76	230/400	2600	1530	50	200